



ELLA ELEMENT 30" Modular Floor Cabinet

SPECIFICATIONS



FSC License Code
FSC-C125053



Available Colors

EBONY

DARK WALNUT

WHITE OAK



Standing Cabinet

Minimalistic Design with Push to Open Under-Mount Slides



Actual Size

Length: 30" • (76,2 cm)

Width: 20" • (50,8 cm)

Height: 34" • (86,3 cm.)

*Measurements can vary +/- 1/8"

NET WEIGHT

Length: 82LBS • (37,2Kg.)

*Weight can vary */100-200gr.

Shipping Size

Length: 31" • (79,2 cm)

Width: 21" • (53,3 cm)

Height: 35" • (89,3 cm.)

SHIPPING WEIGHT

Length: 88LBS • (40Kg.)



DESCRIPTION

Featuring three storage spaces— one drawer on top, an open storage space in the middle, and another drawer at the bottom.

Luxury design with Undermount Push to Open slides for easy opening. No handles

MDF High Quality

Options available 1



Perfect for modular combos with **Ella Element** vanities.

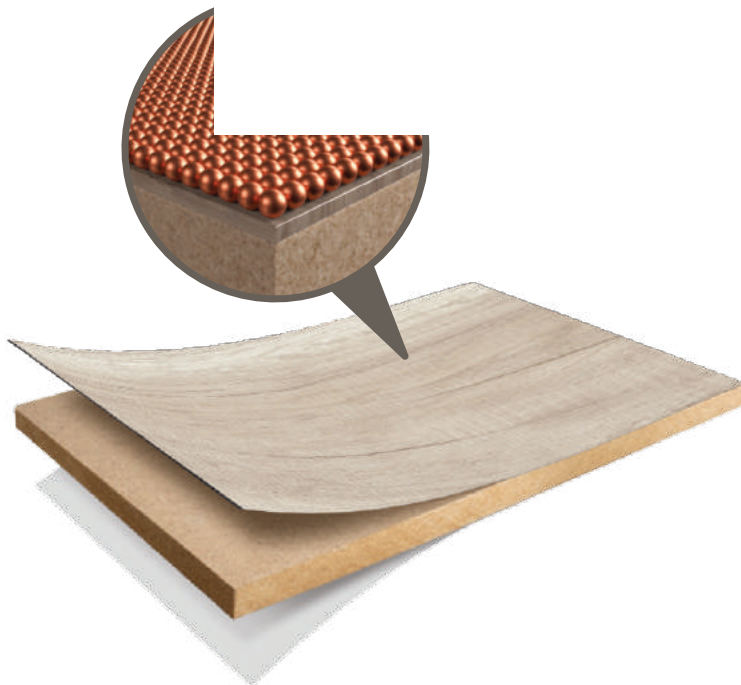

Protection of **Virus Nano Protech** copper nanoparticles, with antiviral and antibacterial effectiveness.

Excellent resistance to surface wear

Textured Wood finish

Build with Environment Friendly Boards





This modern piece not only enhances your bathroom aesthetics with its sleek design but also prioritizes functionality. Perfect for modular setups, this vanity easily combines with others to create customized configurations, allowing you to transform your space with this stylish upgrade where convenience meets contemporary charm.

Crafted with precision, its streamlined aesthetic not only adds a touch of refined style to your bathroom but also enhances the overall functionality of the space.

Colors and Finishes

Ebony



Dark Walnut



White Oak



Ella's vanities are constructed using a collection of boards manufactured in Mexico by Arauco, the world's first Natural Carbon Certified forestry company. This certification signifies that, through its native forests and forestry plantations, Arauco captures more CO₂ than it generates throughout the entire production process. Additionally, Arauco's products originate from sustainably managed forests certified by the FSC.



Environmentally
friendly product.

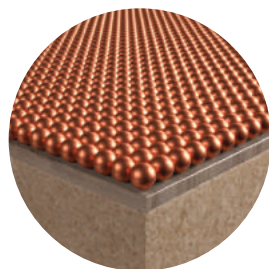

The Arauco Melamine collection of boards features Virus Nano Protech protection. This technology, which utilizes copper nanoparticles, is capable of eliminating up to 99.9% of viruses and bacteria from the melamine surface after 60 minutes of contact and is effective against the virus that causes Covid-19*.

The product is certified to ISO 22196 for bacteria and ISO 21702 for viruses.

*Effectiveness studies were conducted on Human Betacoronavirus OC43, which is considered to be in the same family and subfamily as SARS-CoV-2.



PUSH TO OPEN UNDER-MOUNT SLIDES

All Ella Cabinets are thoughtfully designed with Undermount Push to Open under-mount slides, a cutting-edge feature that not only enhances the seamless and modern aesthetic but also offers exceptional convenience. With these innovative slides, opening your vanity is effortless, eliminating the need for traditional handles and adding a touch of sophistication to every detail of our vanities.

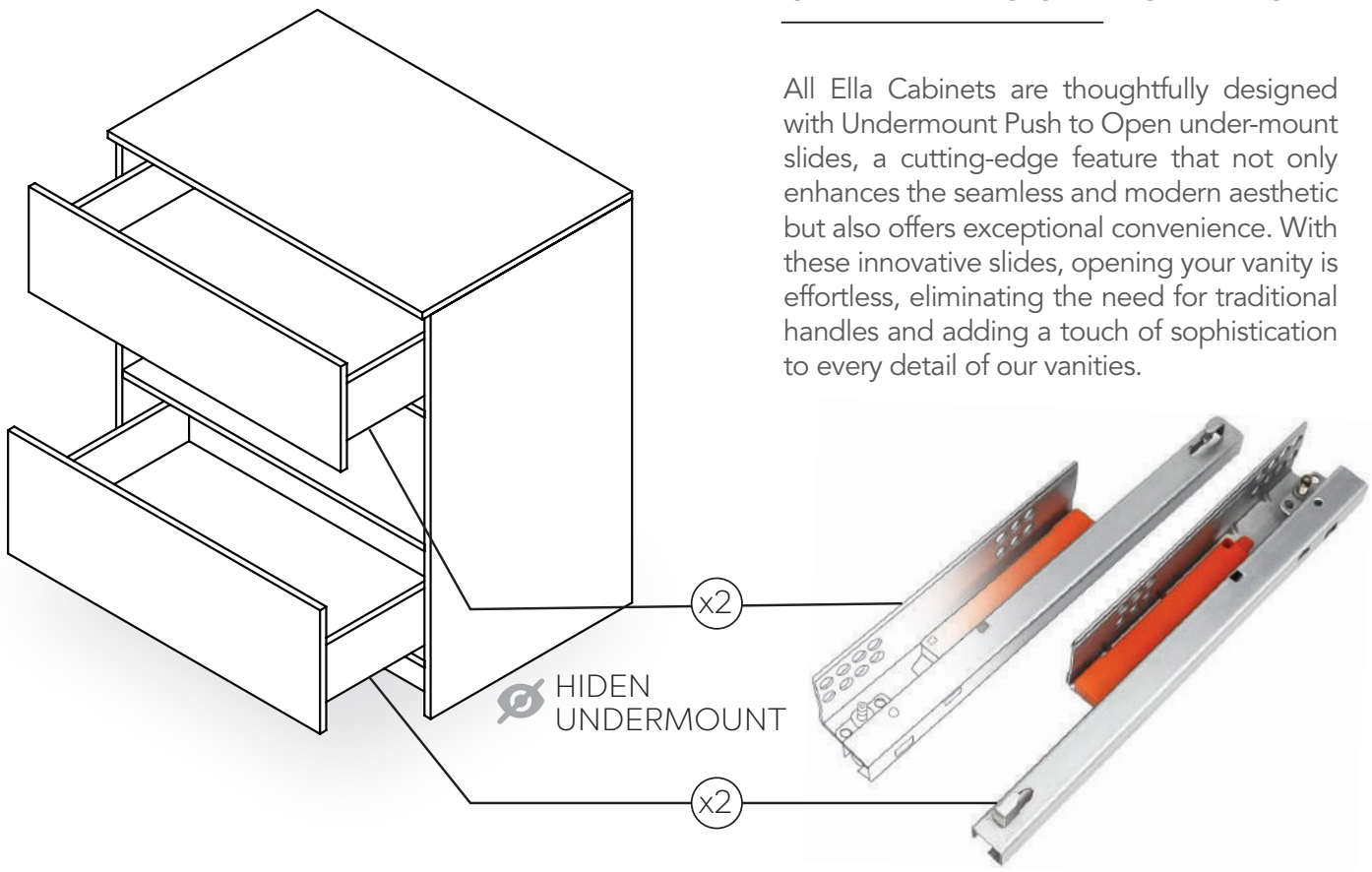

ELEGANCE,
EXCEPTIONAL DESIGN,
EFFORTLESS USE.

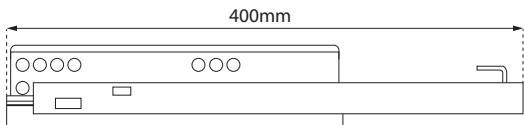

No handles needed

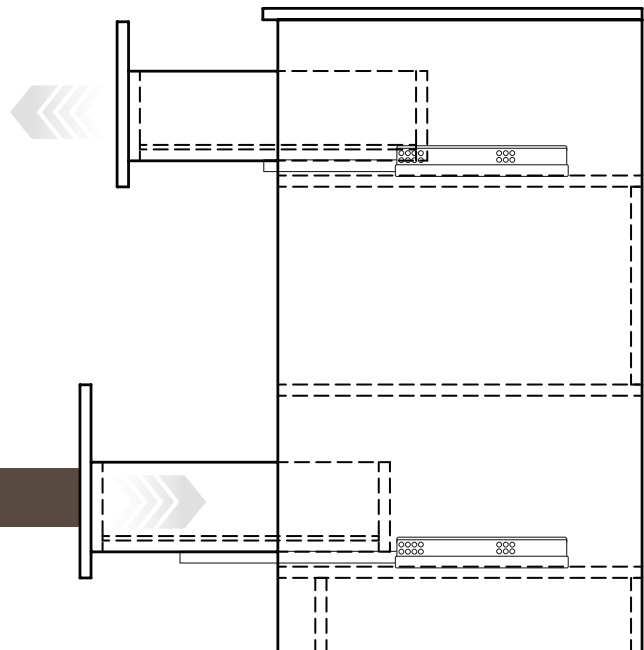



Views & Size

Standing Cabinet

FRONT VIEW

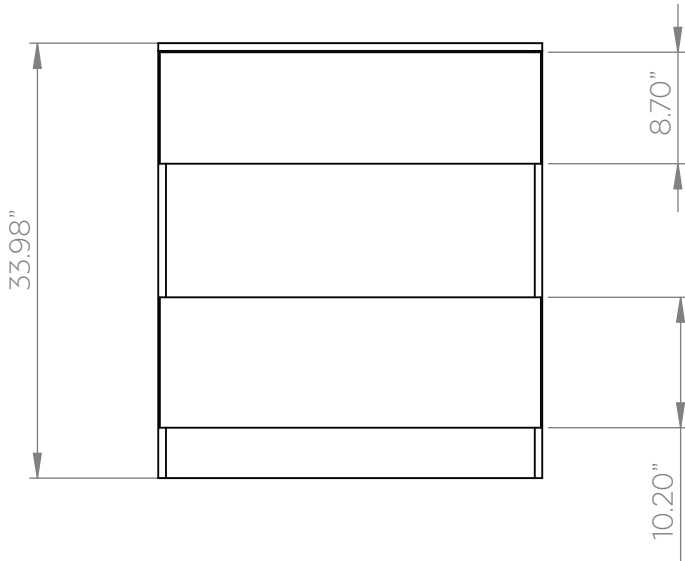

TOP VIEW

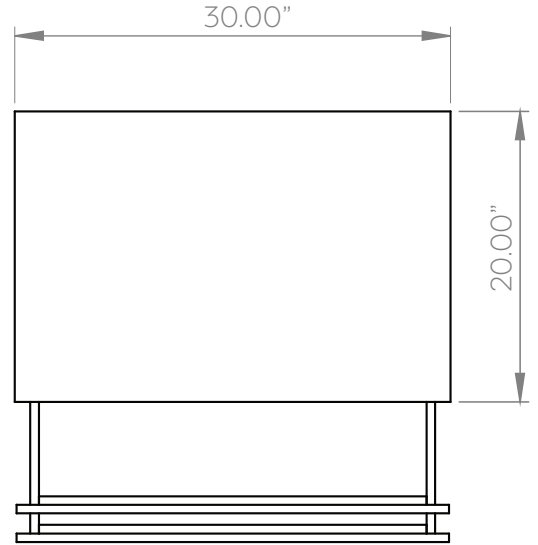

SIDE VIEW

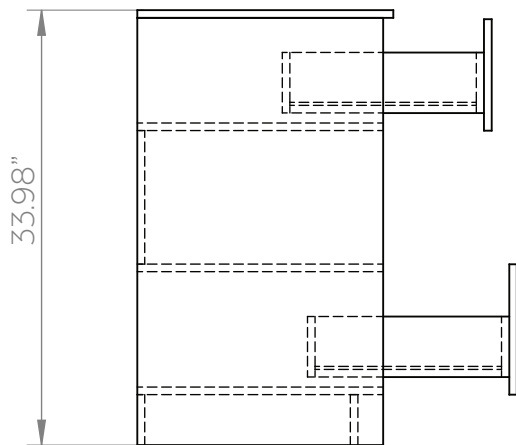

SIDE VIEW

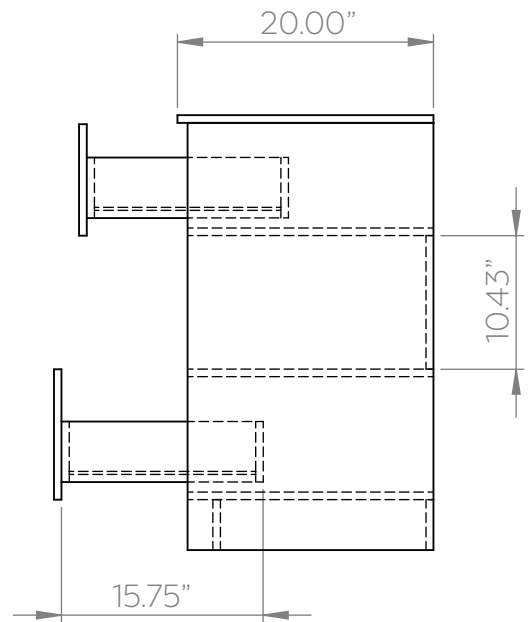

*Measurements can vary +/- 1/8"



The melamine surface of the vanities has a closed and pore-free composition, making cleaning and maintenance very easy. This quality makes them more resistant to daily wear and tear.



Cleaning Recommendations

For daily or light cleaning of your Ella furniture, simply use a lightly dampened soft cloth to remove dust or surface dirt, and be sure to dry the surface afterward. For stubborn stains (glue, paint, crayon, grease, varnish, scale, etc.), consider the following options:

- Mix one tablespoon of bleach per liter of water, lightly dampen a soft cloth with this solution, clean your furniture, and then dry the surface to remove residue.
- Lightly dampen a cloth with a 50% alcohol + 50% water solution.
- Slightly dampen a cloth with Thinner.



Only in extreme cases will it be necessary to resort to cleaners that aid in this process. However, it is important not to overuse these cleaning agents or use them on a daily basis; their usage should be moderate and reserved for occasional cases.

DO NOT USE

- Caustic Soda
- Muriatic Acid
- Scale Remover
- Kitchen Detergents Multipurpose Cleaners
- Abrasive Cloths And Fibers
- Lemon Juice
- Vinegar
- Baking Soda
- Furniture Polish Waxes
- Automotive Waxes
- Any Kind Of Wax